

Embedded DisplayPort Test Adapter

User Manual



WILDER
TECHNOLOGIES

It's all about integrity

Table of Contents

Introduction.....	3
Product Inspection	5
The Embedded DisplayPort Test Adapter Care and Handling Precautions.....	6
General Test Adapter, Cable, and Connector.....	8
Handling and storage.....	8
Visual inspection.....	8
Cleaning	8
Making Connections	8
Electrostatic Discharge Information.....	9
User Model	10
Calibration	13
SOLT.....	14
1X-THRU	15
Mechanical and Environmental Specifications.....	16
Electrical Specifications	20
Wilder Technologies, LLC – Limited Warranty	30
Wilder Technologies, LLC – Terms & Conditions of Sale	31
Compliance with Environmental Legislation	32
WEEE Compliance Statement.....	32
Glossary of Terms	33
Index	34

Introduction

This user's guide documents the Embedded DisplayPort Test Adapter (EDP-TPA) and Calibration Module. The test adapter, shown in Figure 1 and Figure 2, tests Embedded DisplayPort Interface (eDP) cables, devices, or displays against the VESA DisplayPort™ PHY Compliance Test Specification. The Calibration Module, shown on Page 13, is used to zero-out test adapter attributes (using SOLT, with either the 1X-THRU or the 2X-THRU).

The TPA test adapter assembly allows easy access, via SMA connections, to measure or inject Main Link and Auxiliary signals. These test adapters also provide access to LCD_VCC, LCD_GND, LCD_Self_Test, HPD, BL_PWR, BL_GND, BL_ENABLE, BL_PWM_DIM, and four NC – Reserved connections via a 20-position low-speed connector.

NOTE: To avoid damaging the cables, use the handling techniques described in the Care and Handling section before making any connections or configuring a test setup.

Always use a static-safe workstation when performing tests, as explained in the “Electrostatic Discharge Information” section.

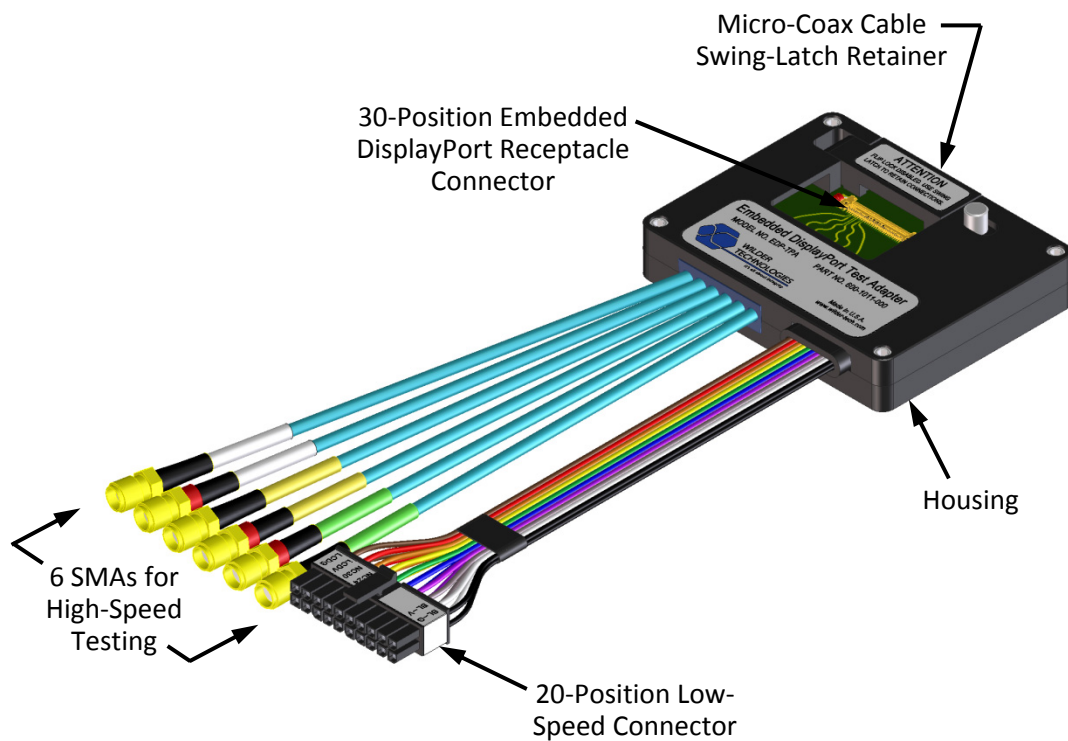

Figure 1. The eDP Test Adapter (Receptacle)

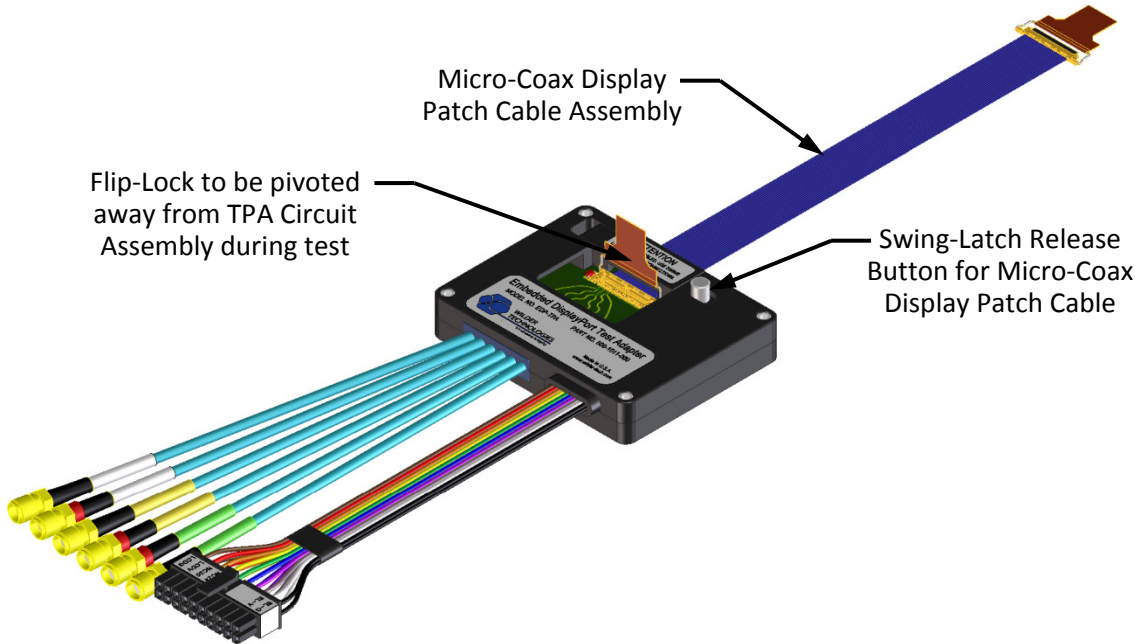

Figure 2. The eDP Test Adapter (Receptacle) shown with the Micro-Coax Display Patch Cable

NOTE: The metal shell of the receptacle (EDP-TPA) connector is configured to tie high-speed ground to chassis ground of the connector. This is because the shell is used to connect to the coax shields of the mating plug.

The low-speed 20-position receptacle connector is keyed and latching (Molex part number 43025-2000). The mating plug connector housing and contact pins for 26-30awg wire are provided with each DP-TPA assembly (Molex part numbers 43020-2001 for the 20-position housing and 43031-0011 for the 26-30awg pin contacts). Replacement plug parts can be purchased through Molex distributors.

Product Inspection

Upon receiving the EDP-TPA from Wilder Technologies, perform the following product inspection:

- Inspect the outer shipping container, foam-lined instrument case, and product for damage. Retain the outer cardboard shipping container until the contents of the shipment have been inspected for completeness and the product has been checked mechanically and electrically. Use the foam-lined instrument case for secure storage of the Wilder Technologies Embedded DisplayPort Test Adapter when not in use.
- Locate the shipping list and verify that all items ordered were received.
- In the unlikely event that the product is defective or incomplete, the “Limited Warranty” section discusses how to contact Wilder Technologies for technical assistance and/or how to package the product for return.

The Embedded DisplayPort Test Adapter Care and Handling Precautions

The Embedded DisplayPort Test Adapter requires careful handling to avoid damage. Improper handling techniques, or using too small a cable bend radius, can damage the coaxial cable connections within the adapter housing or the cables themselves. This can occur at any point along the cable. To achieve optimum performance and to prolong the EDP-TPA's life, observe the following handling precautions:

- **CAUTION 1: Avoid Torque Forces (Twisting)**
While individual high-speed coaxial cables within the test adapter have some rotational freedom, twisting the EDP-TPA as a unit, with one end held stationary, in excess of +/- 90° may damage or severely degrade performance. Adherence to Caution 5 (below) helps to avoid exceeding twist limits.
- **CAUTION 2: Avoid Sharp Cable Bends**
Never bend high-speed coaxial cables or micro-coax cables into a radius of 26 mm (1-inch) or less. Never bend cables greater than 90°. Single or multiple cable bends must be kept within this limit. Bending the EDP-TPA cables less than a 26mm (1-Inch) radius will permanently damage or severely degrade test adapter performance.
- **CAUTION 3: Avoid Cable Tension (Pull Forces)**
Never apply tension (pull forces) to an individual high-speed coaxial cable that is greater than 2.3 kg (5 lbs.), and never apply tension to a mated micro-coax cable that is greater than 0.45 kg (1 lb). To avoid applying tension, always place accessories and equipment on a surface that allows adjustment to eliminate tension on the EDP-TPA and cables. Use adjustable elevation stands or apparatus to accurately place and support the EDP-TPA.
- **CAUTION 4: Connect the EDP-TPA First**
To prevent twisting, bending, or applying tension to the coaxial cables when connecting a EDP-TPA, always attach the EDP-TPA to the device under test (DUT) or cable under test before attaching any SMA connectors. Carefully align the Embedded DisplayPort connectors and then gently push the connectors together until fully seated.

NOTE: To help improve the useful life of the EDP receptacle connector, the “Flip-Lock” feature found on micro-coax cables has been disabled on the test adapter and cannot be engaged. Instead, a cable retention/strain-relief swing-latch is provided and must be used to maintain the connection between the micro-coax cable assembly and the EDP test adapter. To prevent test performance anomalies while testing, the micro-coax cable Flip-Lock feature should be pivoted 90 degrees (perpendicular) from TPA circuit assembly. To release the swing-latch, slide the latch-release away from the mated cable assembly and pivot the swing-latch open.

If the EDP-TPA must be turned or twisted to make connection to the DUT, avoid using the EDP-TPA housing alone to make this occur. Try to distribute the torque forces along the length of the test setup and cabling. If this is not possible, it is recommended to first loosen or disconnect the SMA connections at the EDP-TPA, make the connection to the DUT and then re-tighten or attach the test equipment leads.

- **CAUTION 5: Carefully Make SMA Connections**

To connect the EDP-TPA SMA connectors, follow these steps:

1. Hold the cable stationary by grasping the cable at the black heat-shrink section near the SMA connector.
2. Insert the mating SMA barrel and hand-tighten the free-spinning SMA nut onto the connector while avoiding pulling, bending, or twisting the EDP-TPA coaxial cable.
3. The EDP-TPA SMA connectors have flats that accept an open-end 1/4-inch or 6.5mm wrench. When attaching instrument cables to the EDP-TPA, it is recommended that the EDP-TPA SMA connectors be mechanically held and the test leads be tightened to the equipment manufacturer's torque recommendations, normally 5 in-lbs, using a 5/16-inch open-end wrench.

If the test set-up requires repositioning, first loosen or disconnect the SMA connections to avoid twisting, bending, or tension.

NOTE: A drop in signal amplitude by half or 6db during the testing of a lane may indicate that a cable has been mechanically pulled free of coaxial cable connections internal to the assembly. This could be determined by checking if the cable has any lateral play relative to the TPA. This would only occur when the TPA has exceeded the pull force as specified within the mechanical specification. If the cable cannot be re-seated, the test adapter will need to be sent back to the factory for service.

- **CAUTION 6: Independently Support Instrument Cables or Accessories**

Excessive weight from instrument cables and/or accessories connected to the EDP-TPA can cause damage or affect the test adapter performance. Be sure to provide appropriate means to support and stabilize all test set-up components.

General Test Adapter, Cable, and Connector

Observing simple precautions can ensure accurate and reliable measurements.

Handling and storage

Before each use of the EDP-TPA, ensure that all connectors are clean. Handle all cables carefully and store the EDP-TPA in the foam-lined instrument case when not in use, if possible. Do not set connectors contact end down. Install the SMA protective end caps when the EDP-TPA is not in use.

Visual inspection

Be sure to inspect all cables carefully before making a connection. Inspect all cables for metal particles, scratches, deformed threads, dents, or bent, broken, or misaligned center conductors. Do not use damaged cables.

Cleaning

If necessary, clean the connectors using low-pressure (less than 60 PSI) compressed air or nitrogen with an effective oil-vapor filter and condensation trap. Clean the cable threads, if necessary, using a lint-free swab or cleaning cloth moistened with isopropyl alcohol. Always completely dry a connector before use. Do not use abrasives to clean the connectors. Re-inspect connectors, making sure no particles or residue remains.

Making Connections

Before making any connections, review the “Care and Handling Precautions” section. Follow these guidelines when making connections:

- Align cables carefully
- Make preliminary connection lightly
- To tighten, turn connector nut only
- Do not apply bending force to cable
- Do not over-tighten preliminary connections
- Do not twist or screw-in cables
- Use a torque wrench, and do not tighten past the “break” point of the torque wrench

Electrostatic Discharge Information

Protection against electrostatic discharge (ESD) is essential while connecting, inspecting, or cleaning the EDP-TPA test adapter and connectors attached to a static-sensitive circuit (such as those found in test sets).

Electrostatic discharge can damage or destroy electronic components. Be sure to perform all work on electronic assemblies at a static-safe work station, using two types of ESD protection:

- Conductive table-mat and wrist-strap combination
- Conductive floor-mat and heel-strap combination

When used together, both of these types provide a significant level of ESD protection. Used alone, the table-mat and wrist-strap combination provide adequate ESD protection. To ensure user safety, the static-safe accessories must provide at least 1 M Ω of isolation from ground. Acceptable ESD accessories may be purchased from a local supplier.

WARNING: These techniques for a static-safe work station should not be used when working on circuitry with a voltage potential greater than 500 volts.

User Model

The Embedded DisplayPort TPA supports all testing of the DisplayPort CTS PHY 1.1. It is capable of performing well beyond the scope of measurements contained in the CTS PHY, limited only by the specifications, environmental, care and handling as stated in this document.

The following examples are suggestions for possible testing setups.

In this first example, an Embedded DisplayPort TPA and micro-coax patch cable act as a sink:

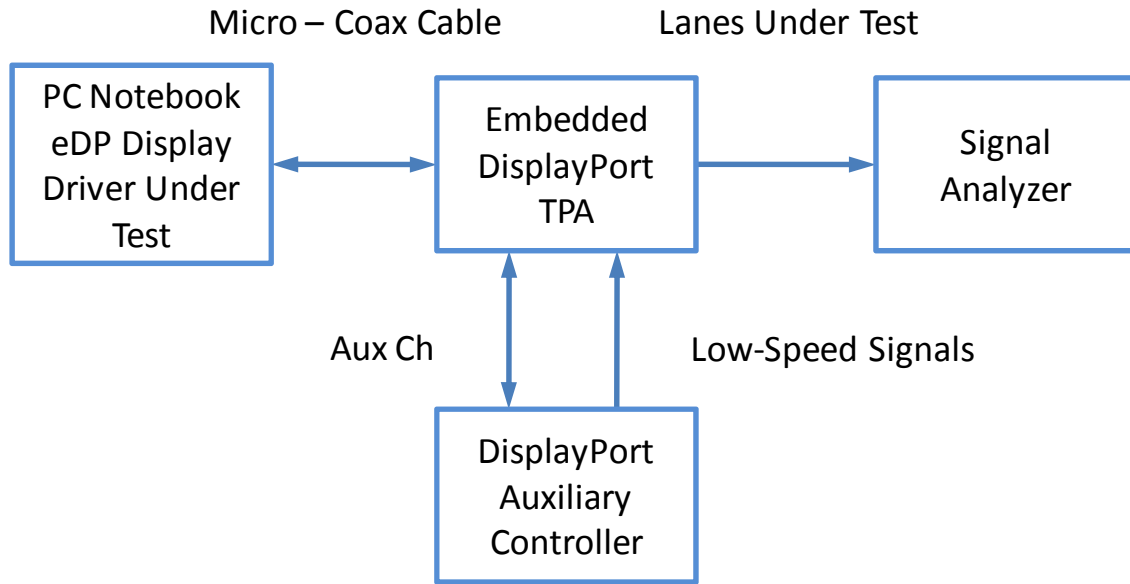

Embedded DisplayPort Test Adapter User Manual

In the second example, the Embedded DisplayPort TPA and micro-coax patch cable act as a source:

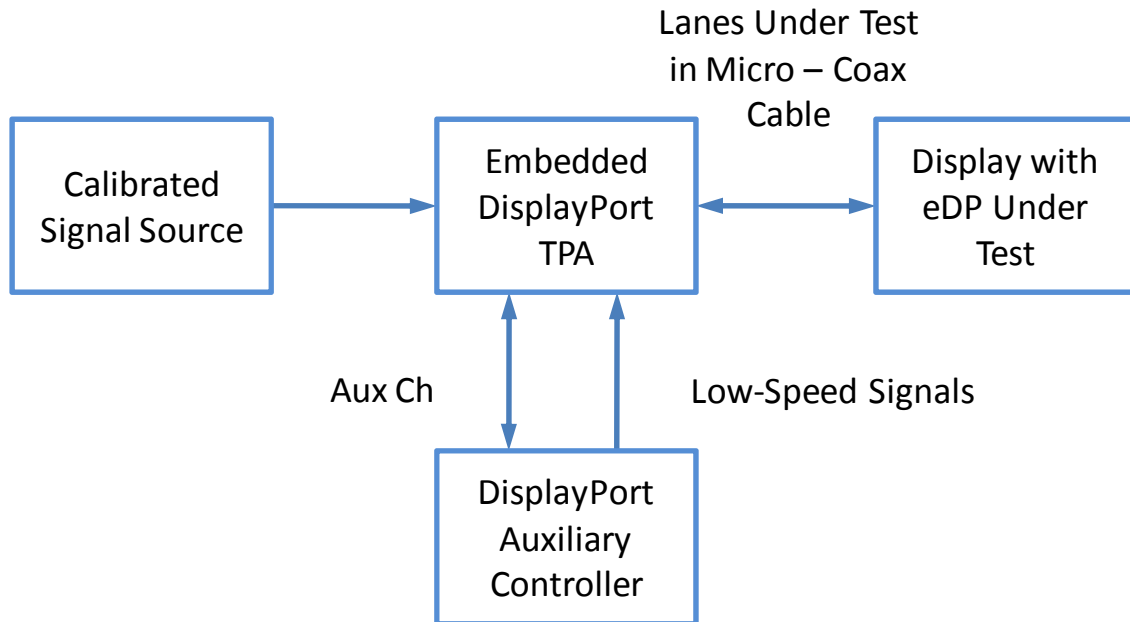

The third example shows two Embedded DisplayPort receptacle TPAs acting as source and sink:

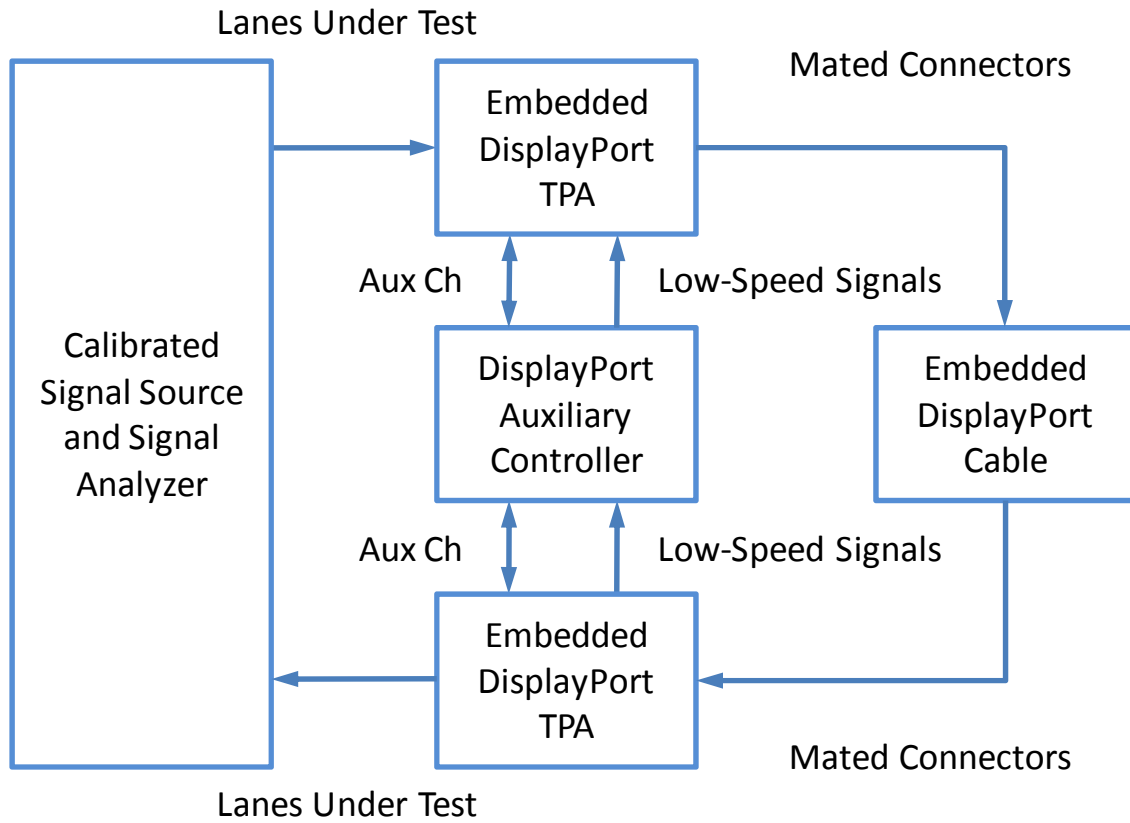

Calibration

The Embedded DisplayPort Receptacle Test Adapter is a passive component. Therefore, calibration for the errors generated must occur within the test instrumentation that drives the sink or looks at the response of the source.

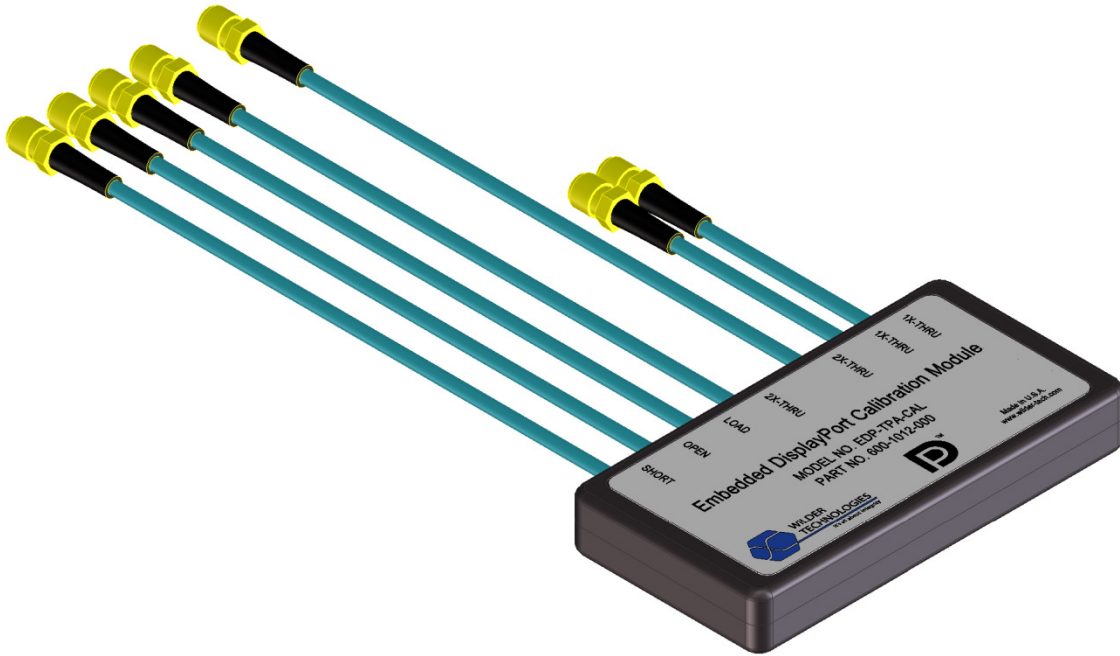

Figure 3. Calibration module (EDP-TPA-C) showing standard 6-inch cable on SOLT and 3-inch cables connected to the 1X-THRU.

SOLT

SHORT, OPEN, LOAD, and 2X-THRU (SOLT) are calibration standards used to compensate for errors associated with the TPA when used for Jitter measurement, TDR, TDT, and VNA testing. SOLT represents the same electrical length and losses as the TPA through the Embedded DisplayPort connector pad, and enables the test engineer to compensate for the following six repeatable, systematic errors that occur when moving the reference plane:

- Signal leakage effects: *Directivity errors*
- Signal leakage effects: *Crosstalk errors*
- Reflection effects: *Source Impedance Mismatching errors*
- Reflection effects: *Load Impedance Mismatching errors*
- Bandwidth effects: *Receiver Transmission in Test Equipment errors*
- Bandwidth effects: *Receiver Reflection-tracking in Test Equipment errors*

These errors need to be corrected on each port. Refer to the Instrument Manual for instructions on the instrument's specific calibration process.

NOTE: The reference plane is the boundary, both physically and electrically, between the calibrated and uncalibrated portions of the circuit. Everything outside the reference plane is considered part of the DUT. Any instrument that does not use calibration defines the DUT as the total of externally connected components. If the TPA-C is not used, all of the Embedded DisplayPort TPA and the 6-inch cables, as well as cables connecting the 6-inch cables to the test instrument, would be a part of the DUT.

Non-repeatable errors, such as drift or random errors can be reduced but not corrected. Drift errors aggregate over time or with environmental changes such as temperature shift. To eliminate drift errors, perform another calibration.

A random error cannot be corrected through calibration since the error occurred randomly. Random errors are typically associated with either test instrument noise or test repeatability problems. Reduce test instrument noise by increasing source power, lowering the IF bandwidth, or averaging results over multiple sweeps. Reduce test repeatability problems through the use of a torque wrench or, again, by averaging over multiple sweeps.

1X-THRU

The 1X-THRU is a calibration feature used to calibrate time domain instrumentation (for example, pre-emphasized pulse generators or AWGs, arbitrary waveform generators). 1X-THRU calibration compensates two error sources – cable losses and group delay:

- **Cable Losses** – Cable losses associated with the Embedded DisplayPort TPA, and its respective cabling that's connected to the test source, consist of skin loss and, to a lesser extent, dielectric loss. Pre-emphasis or de-emphasis is used at the signal source to correct for these cable losses. Pre-emphasis is a boost of the signal level just after an edge transition; de-emphasis is a reduction in the low-speed amplitude of the signal source. Typically, on a de-emphasized signal the levels have to be reset to attain the same output levels. Resultant signals from either pre-emphasis or de-emphasis are identical relative to the DUT.

For the purposes of this discussion, pre-emphasis will be used. To set the pre-emphasis, first determine the amount of signal boost by connecting the signal source, via the 1X-THRU and the respective cable used to connect the DUT to the source to a high-speed oscilloscope or a jitter measurement device. Trigger the oscilloscope or jitter measurement device using a trigger from the source. The trigger, a single event, indicates the start of the signal being sent to the DUT. Adjust pre-emphasis to maximize the eye opening.

- **Group Delay** – Group delay is the second error source for 1X-THRU calibration. When the DUT generates an output signal, it can be used to measure delay. To create a baseline delay measurement, connect the output signal cable to the input signal cable and the 1X-THRU. To determine corrected DUT delay, subtract this baseline measurement from the DUT delay measurements.

Mechanical and Environmental Specifications

NOTE: All specifications in this manual are subject to change.

Table 1. General Specifications

ITEM	DESCRIPTION
Usage Environment	Controlled indoor environment
Test Adapter Length (w/standard cables)	190.5 mm +/- 2 mm (7.50 inches +/- .08 inches) (Characteristic)
Operating Temperature	0°C to +55°C (32°F to +131°F) (Characteristic)
Storage Temperature	-40°C to +70°C (-40°F to +158°F) (Characteristic)

EDP-TPA Cable Pinout

The EDP-TPA cables provide six SMA connectors (Main Link and Auxiliary signals) and one low-speed connector. Labels clearly mark each cable or connector. The following figure refers to pin-description tables for each of the two connector types.

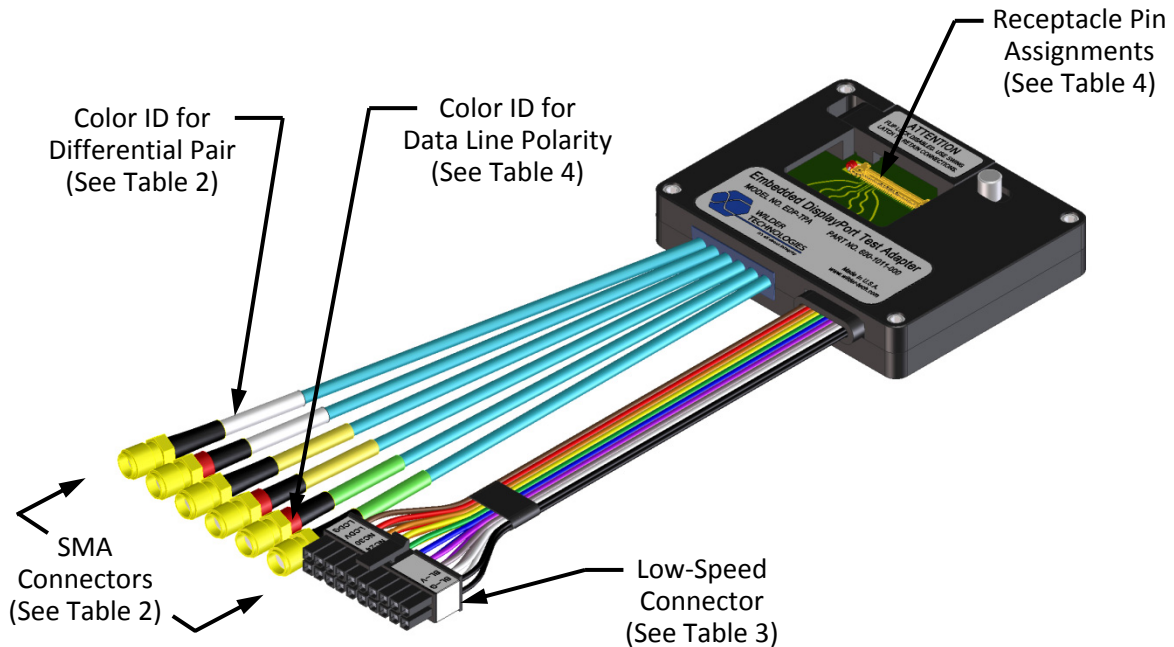

Figure 4. Cable Connectors

Table 2. SMA Cable Connectors (High-Speed)

LABEL	COLOR ID FOR DIFFERENTIAL PAIR	DESCRIPTION
Lane0_N	White	Differential Data Lane 0- for Source or Sink
Lane0_P	White	Differential Data Lane 0+ for Source or Sink
Lane1_N	Yellow	Differential Data Lane 1- for Source or Sink
Lane1_P	Yellow	Differential Data Lane 1+ for Source or Sink
AUX_P	Green	Differential Auxiliary Channel Positive (+)
AUX_N	Green	Differential Auxiliary Channel Negative (-)

Table 3. EDP-TPA 20-Position Cable Connector “P2” (Low-Speed)

LABEL	P2 PIN NO.	COLOR ID FOR TPA (RECEPTACLE)	DESCRIPTION
LCDG	1	Brown	LCD logic and driver ground
LCDV	2	Red	LCD logic and driver power
NC-1	3	Orange	LCD Manufacturers use
NC25	4	Yellow	LCD Manufacturers use
BLDM	5	Green	Backlight Dim
BLDN	6	Blue	Backlight Enable
HPD	7	Violet	Hot Plug Detect
SELF	8	Gray	LCD panel self enable test
BL-V	9	White	Backlight power
BL-G	10	Black	Backlight ground
LCDG	11	Brown	LCD logic and driver ground
LCDV	12	Red	LCD logic and driver power
NC30	13	Orange	LCD Manufacturers use
NC24	14	Yellow	LCD Manufacturers use
-	15	Green	Not used
-	16	Blue	Not used
-	17	Violet	Not used
-	18	Gray	Not used
BL-V	19	White	Backlight power
BL-G	20	Black	Backlight ground

Table 4. Embedded DisplayPort Receptacle “P1” Pin Assignments

Pin Description	Connector P1 Pin Number	Destination Number	Color ID for Data Line Polarity	Color Identification
NC - Reserved	1	NC-1 (P2-1)	N/A	Orange Insulation
High speed Ground	2	Ground	N/A	N/A
ML Lane 1 (n)	3	LANE 1_N	Black	White Label
ML Lane 1 (p)	4	LANE 1_P	Red	White Label
High speed Ground	5	Ground	N/A	N/A
ML Lane 0 (n)	6	LANE 0_N	Black	Yellow Label
ML Lane 1 (p)	7	LANE 0_P	Red	Yellow Label
High speed Ground	8	Ground	N/A	N/A
AUX CH (p)	9	AUX_P	Red	Green Label
AUX CH (n)	10	AUX_N	Black	Green Label
High speed Ground	11	Ground	N/A	N/A
LCD VCC	12,13	LCDV (P2-2, 12)	N/A	Red Insulation
LCD Self Test	14	SELF (P2-8)	N/A	Gray Insulation
LCD GND	15,16	LCDG (P2-1, 11)	N/A	Brown Insulation
Hot Plug Detect	17	HPD (P2-7)	N/A	Violet Insulation
Backlight GND	18, 19, 20, 21	BL-G (P2-10, 20)	N/A	Black Insulation
Backlight ENABLE	22	BLEN (P2-6)	N/A	Blue Insulation
Backlight PWM Dimming	23	BLDM (P2-5)	N/A	Green Insulation
NC - Reserved	24	NC24 (P2-14)	N/A	Yellow Insulation
NC - Reserved	25	NC25 (P2-4)	N/A	Yellow Insulation
Backlight Power	26, 27, 28, 29	BL-V (P2-9, 19)	N/A	White Insulation
NC - Reserved	30	NC30 (P2-13)	N/A	Orange Insulation



Electrical Specifications

NOTE: All specifications in this manual are subject to change.

Table 5. Electrical Specifications

SPECIFICATION	MINIMUM	TYPICAL	MAXIMUM	NOTES
Insertion Loss (GHz), at -3 db	13	16.0		2X-THRU with six inch cables
Return Loss (GHz), at -20 db	10	14.5		2X-THRU with six inch cables
Insertion Loss (GHz), at -3 db		19.5		1X-THRU with three inch cables
Return Loss (GHz), at -20 db		8.5		1X-THRU with three inch cables
VSWR, at 10 GHz	1.21:1			2X-THRU with six inch cables
Differential Impedance, coaxial cable connections (ohms) 100ps Rise Time	100		107.5	All lanes and Aux CH, Receptacle
Differential Impedance (ohms) 100ps Rise Time	95		105	All lanes and Aux CH, Receptacle TPA, and Receptacle TPA with Micro-Coax Patch Cable, excluding Coaxial Cable connections and Primary Connector
Impedance, coaxial cable connections (ohms) 100ps Rise Time	50		53.75	All lanes and Aux CH, Receptacle
Impedance (ohms) 100ps Rise Time	47.5		52.5	All lanes and Aux CH, Receptacle TPA, and Receptacle TPA with Micro-Coax Patch Cable, excluding Coaxial Cable connections and Primary Connector
Impedance (ohms) 100ps Rise Time	47.5		52.5	SHORT, OPEN, LOAD, 1X-THRU, and 2X-THRU
Intra-lane Skew (ps)	-6		6	All lanes and Aux CH, Receptacle
Inter-lane Skew (ps)	-6		6	All lanes and Aux CH, Receptacle
NEXT (db), at 13 GHz, at 6.75 GHz at 4.05 GHz	-40	-53 -57		All lanes and Aux CH, single aggressor, without EDP connector, with six inch cables and terminations
Current Carrying (A) Back light Power LCD Vcc	4.0? 2.0?			

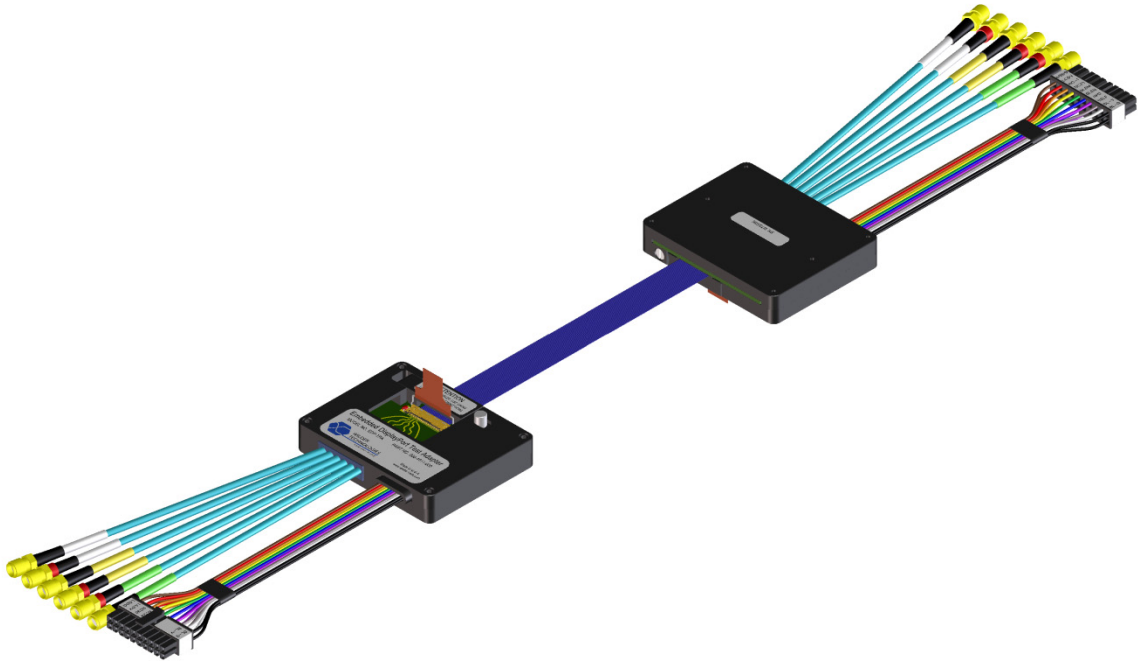

Figure 5. "As-Tested" Configuration ("Mated Pair" in the figures that follow)

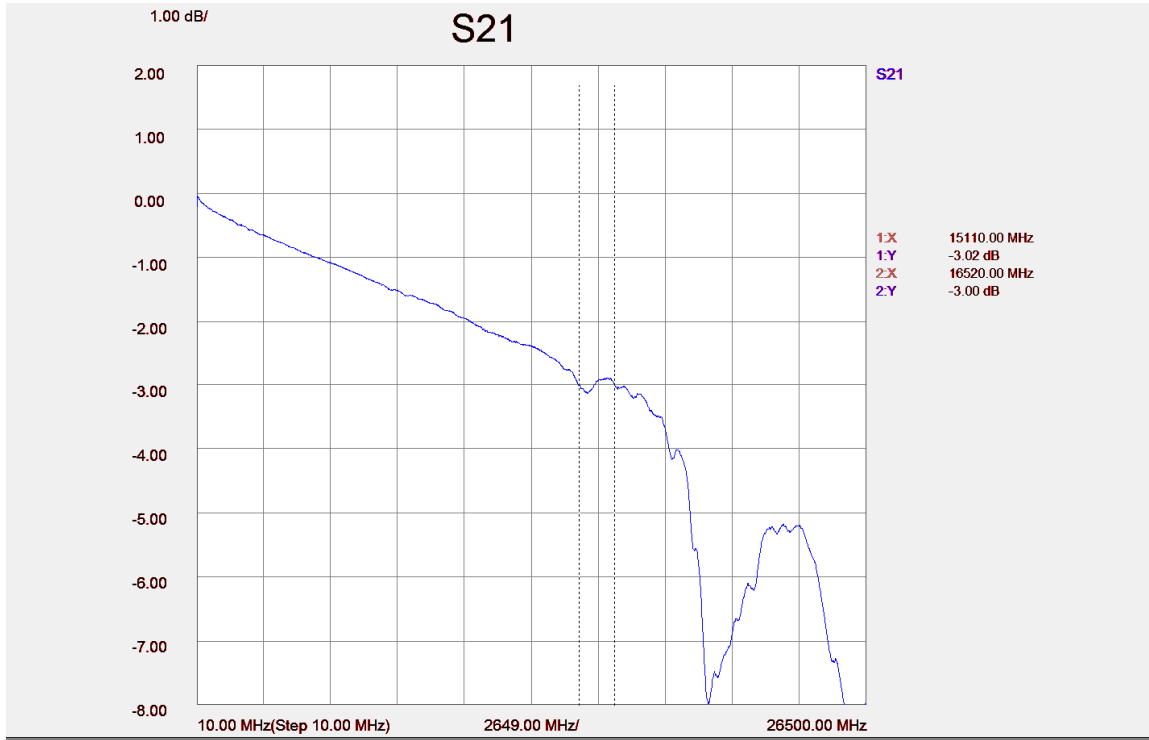

Figure 6. Typical 2X-THRU insertion loss

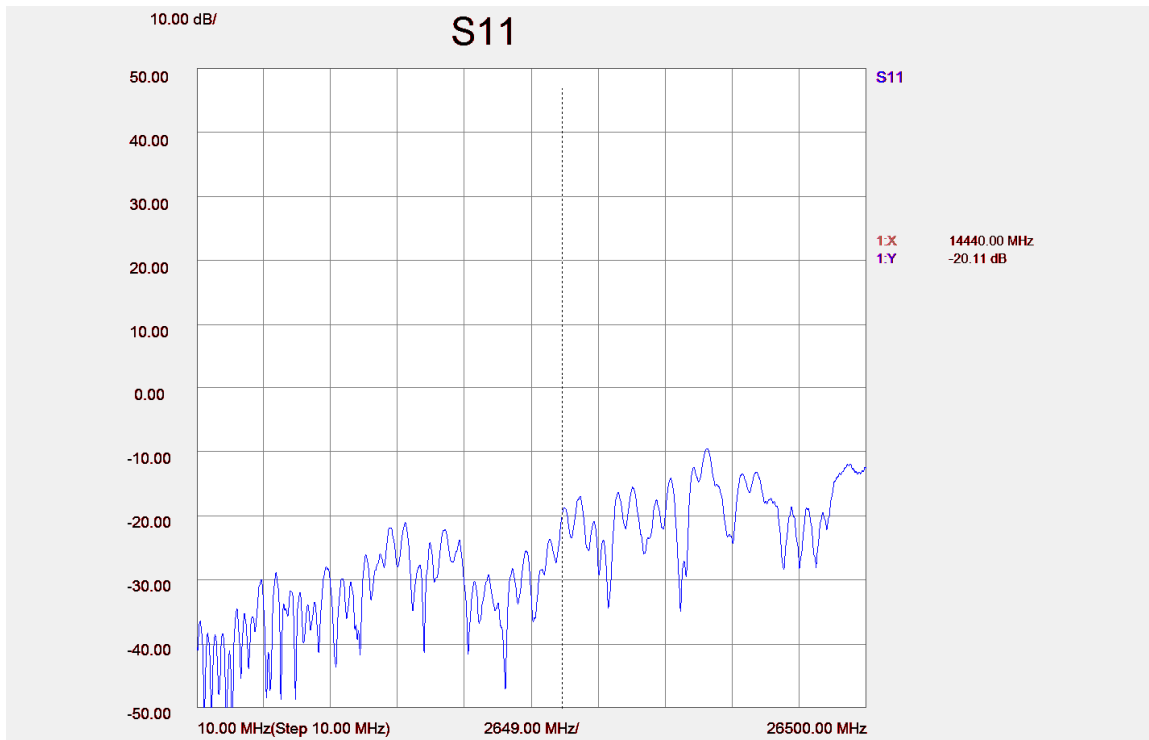

Figure 7. Typical 2X-THRU return loss

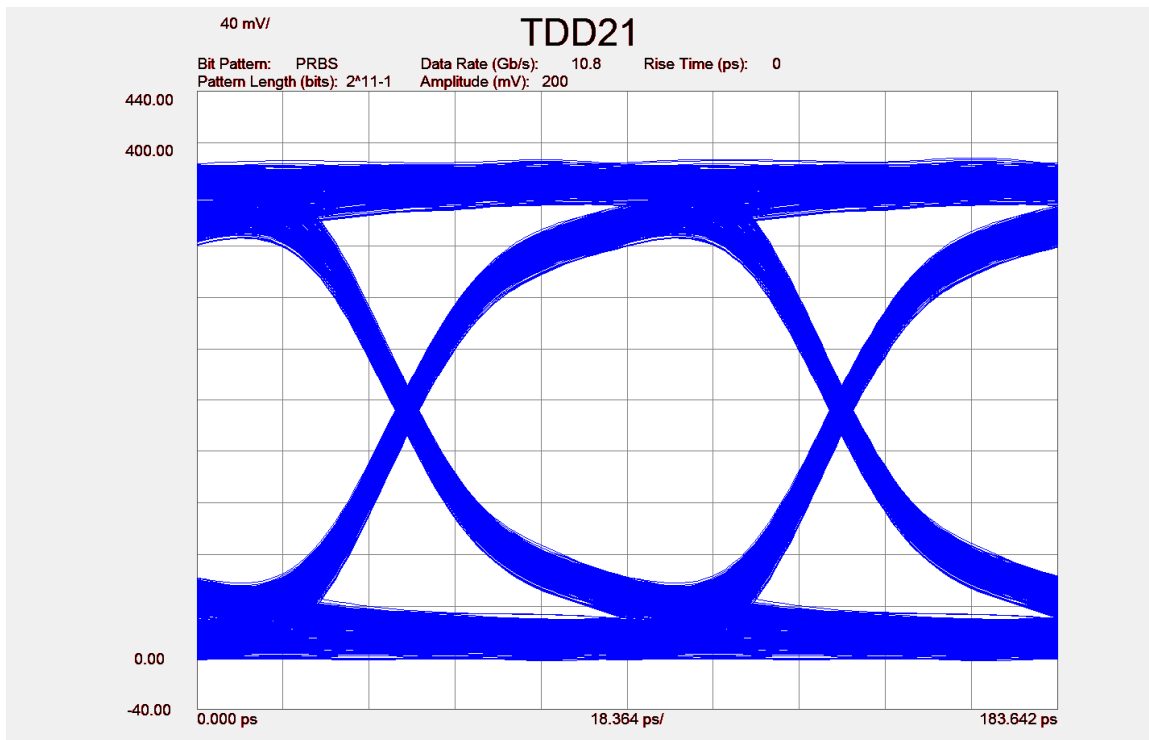
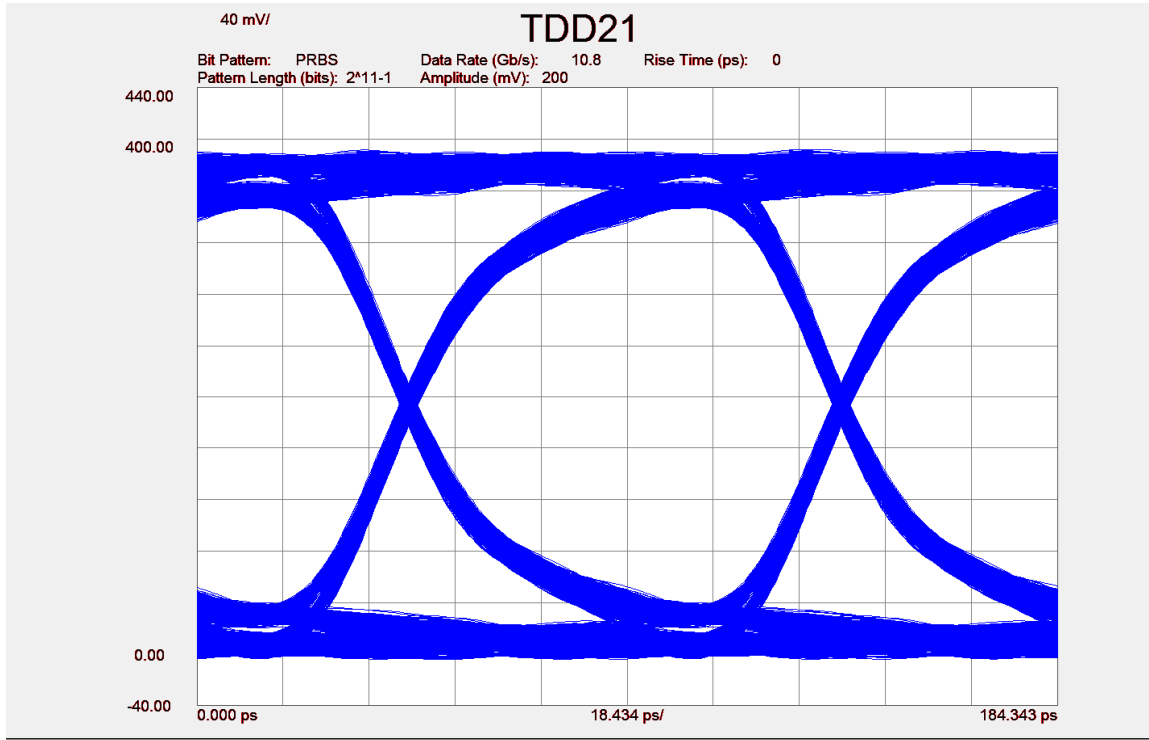

Figure 8. Typical mated pair 10.8 Gb/s eye diagram, with calibration (top) and without calibration (bottom)

Parameter Measurement Result

Name	Measurement Result
Eye Level Zero(mV)	24.78
Eye Level One(mV)	364.04
Eye Level Mean(mV)	194.41
Eye Amplitude(mV)	339.26
Eye Height(mV)	263.18
Eye Height(db)	-5.80
Eye Width	8.75e-011
Eye Opening Factor	0.78
Eye Signal_to_Noise	10.08
Eye Duty Cycle Dist	4.92e-014
Eye Duty Cycle Dist(%)	0.05
Eye Rise Time (20-80)	2.89e-011
Eye Fall Time (80-20)	2.89e-011
Eye Jitter(PP)	5.13e-012
Eye Jitter(RMS)	1.04e-012

S Param DUT Files Meas

Parameter Measurement Result

Name	Measurement Result
Eye Level Zero(mV)	32.17
Eye Level One(mV)	352.84
Eye Level Mean(mV)	192.50
Eye Amplitude(mV)	320.67
Eye Height(mV)	243.74
Eye Height(db)	-6.13
Eye Width	8.66e-011
Eye Opening Factor	0.76
Eye Signal_to_Noise	8.46
Eye Duty Cycle Dist	-1.53e-013
Eye Duty Cycle Dist(%)	-0.17
Eye Rise Time (20-80)	3.10e-011
Eye Fall Time (80-20)	3.09e-011
Eye Jitter(PP)	5.95e-012
Eye Jitter(RMS)	1.35e-012

S Param DUT Files Meas

Figure 9. Typical mated pair 10.8 Gb/s eye data, with calibration (top) and without calibration (bottom)

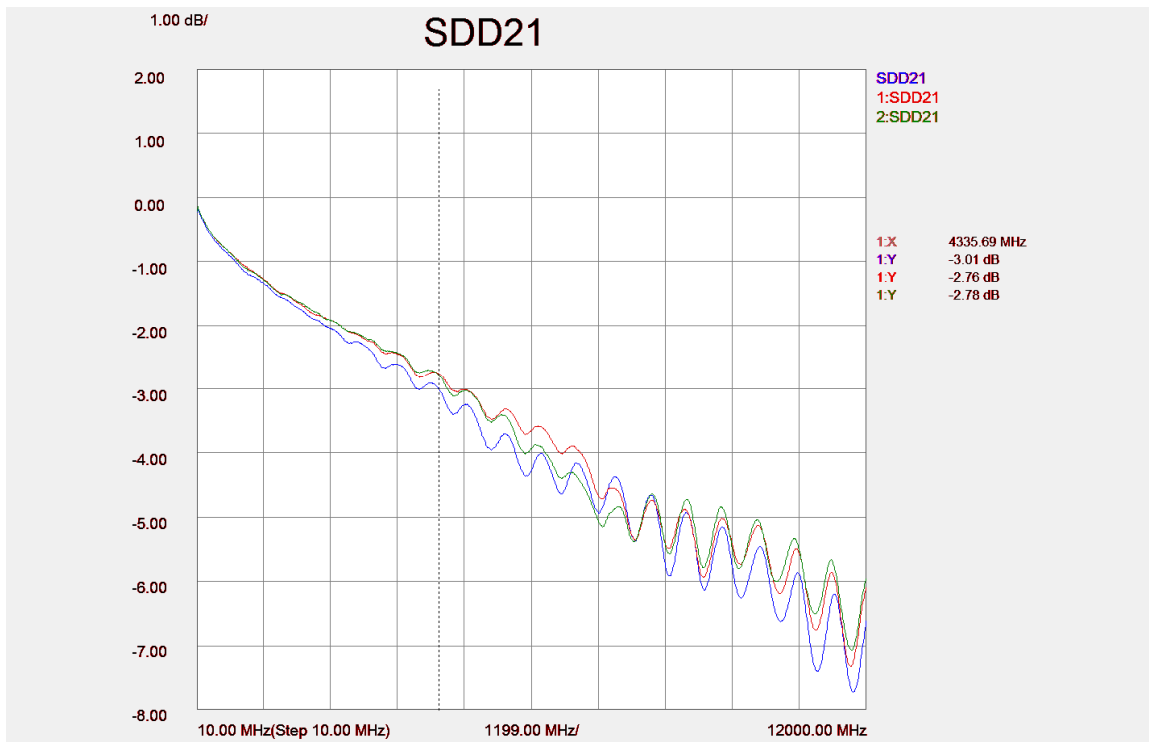
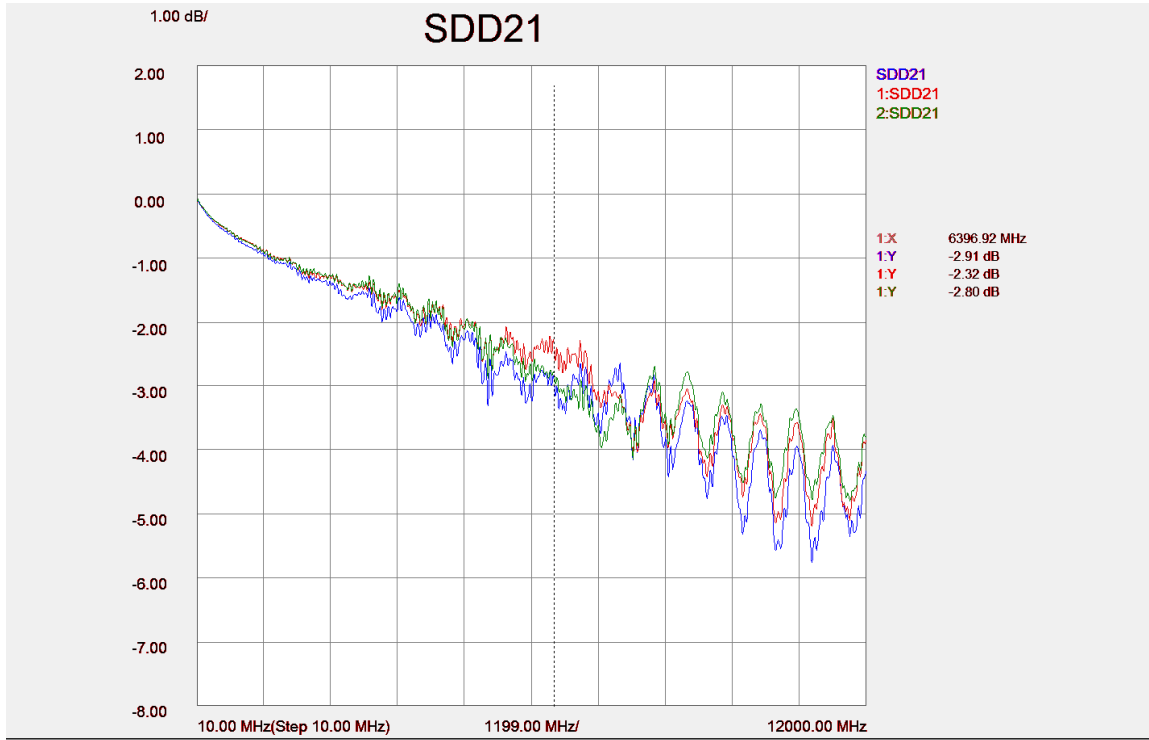

Figure 10. Typical mated pair balanced insertion loss, with calibration (top) and without calibration (bottom)

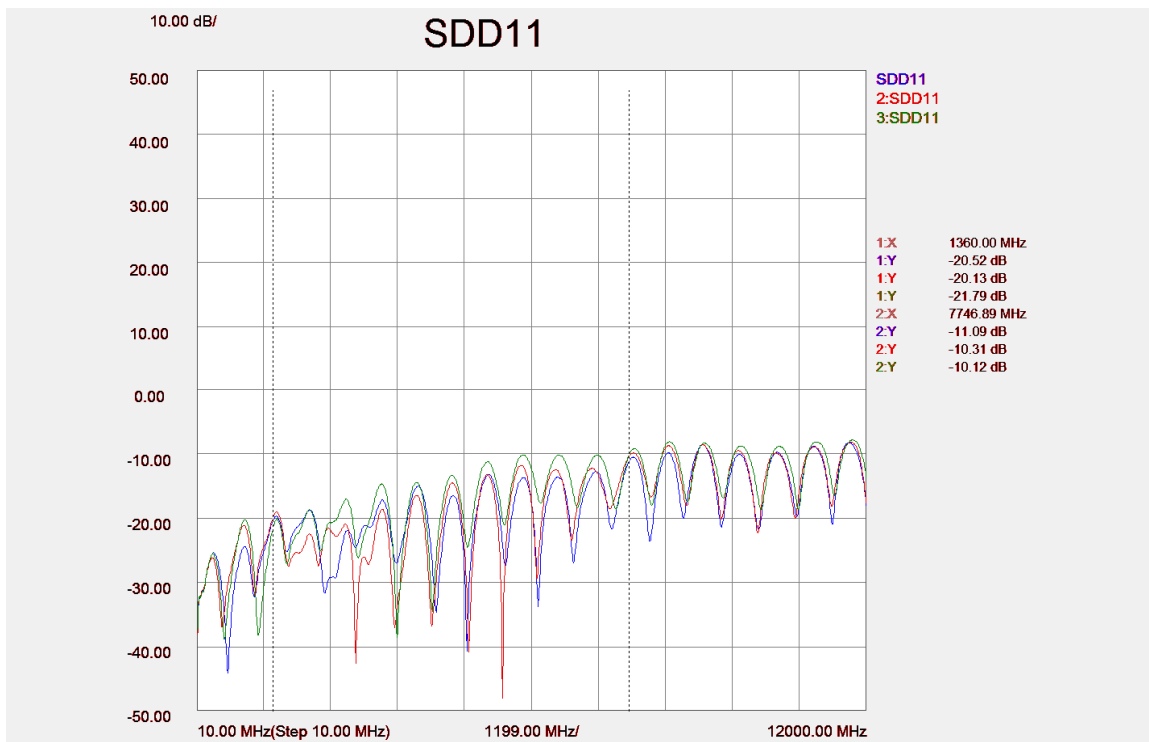
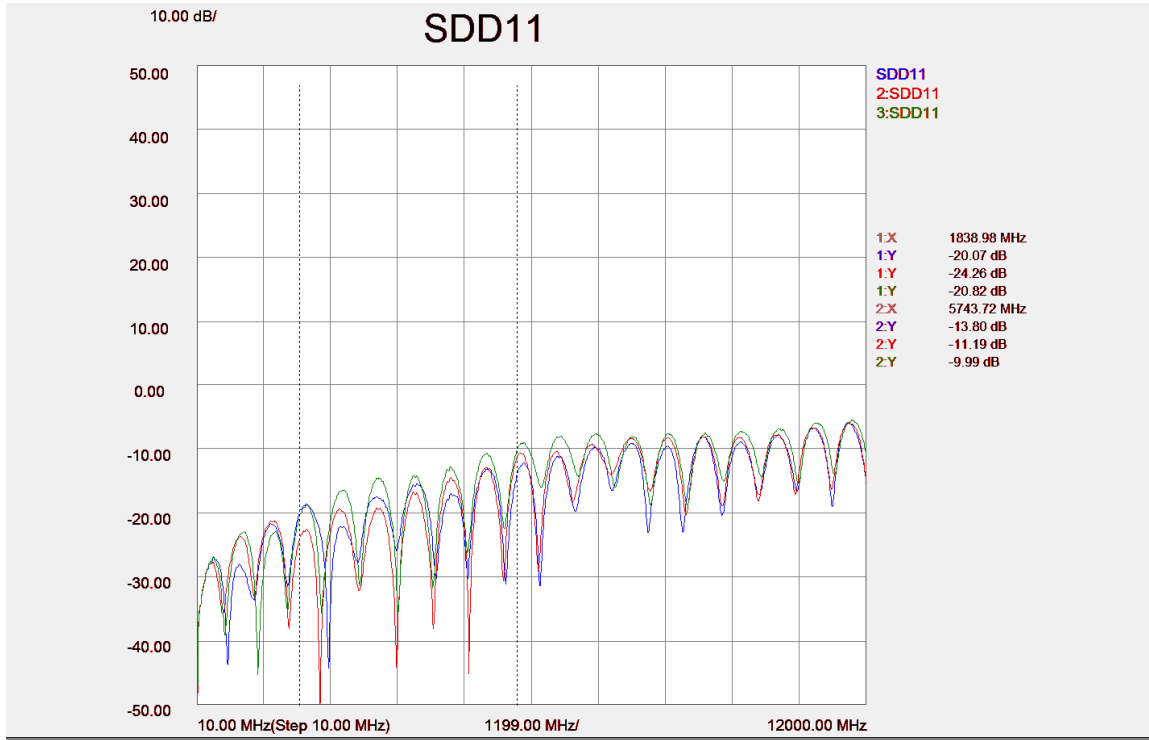

Figure 11. Typical mated pair balanced return loss, with calibration (top) and without calibration (bottom)

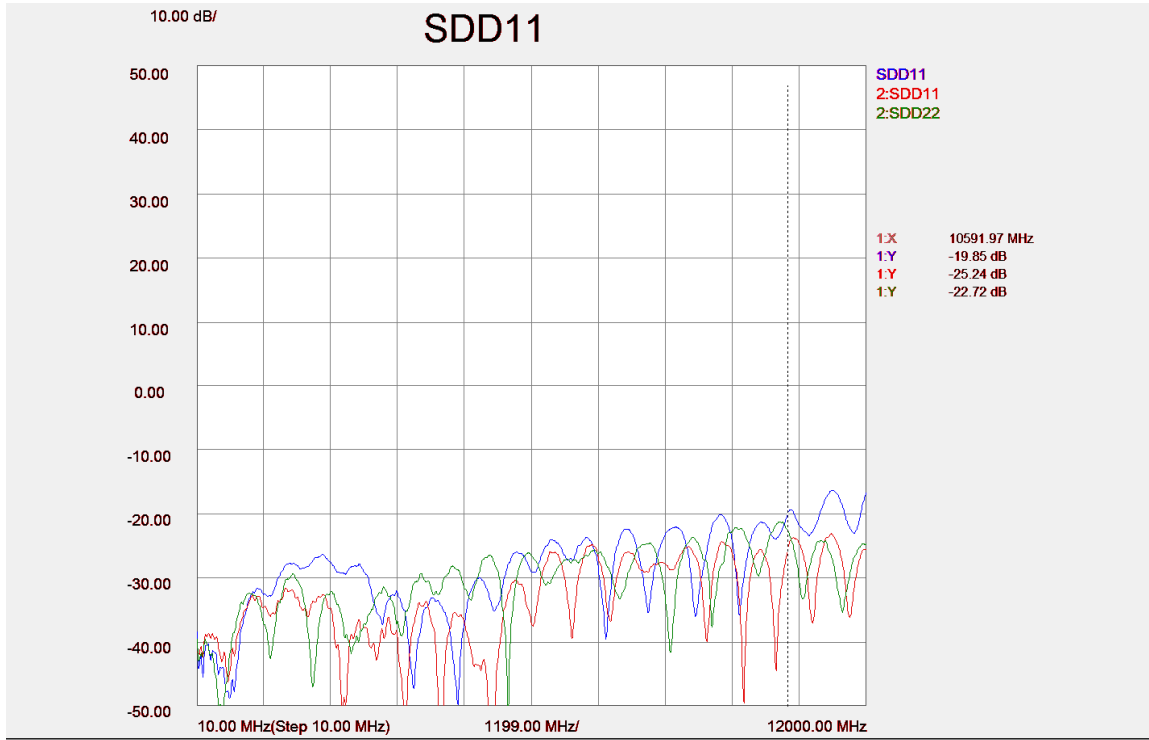

Figure 12. Typical balanced return loss, without connector, all lanes terminated at both ends

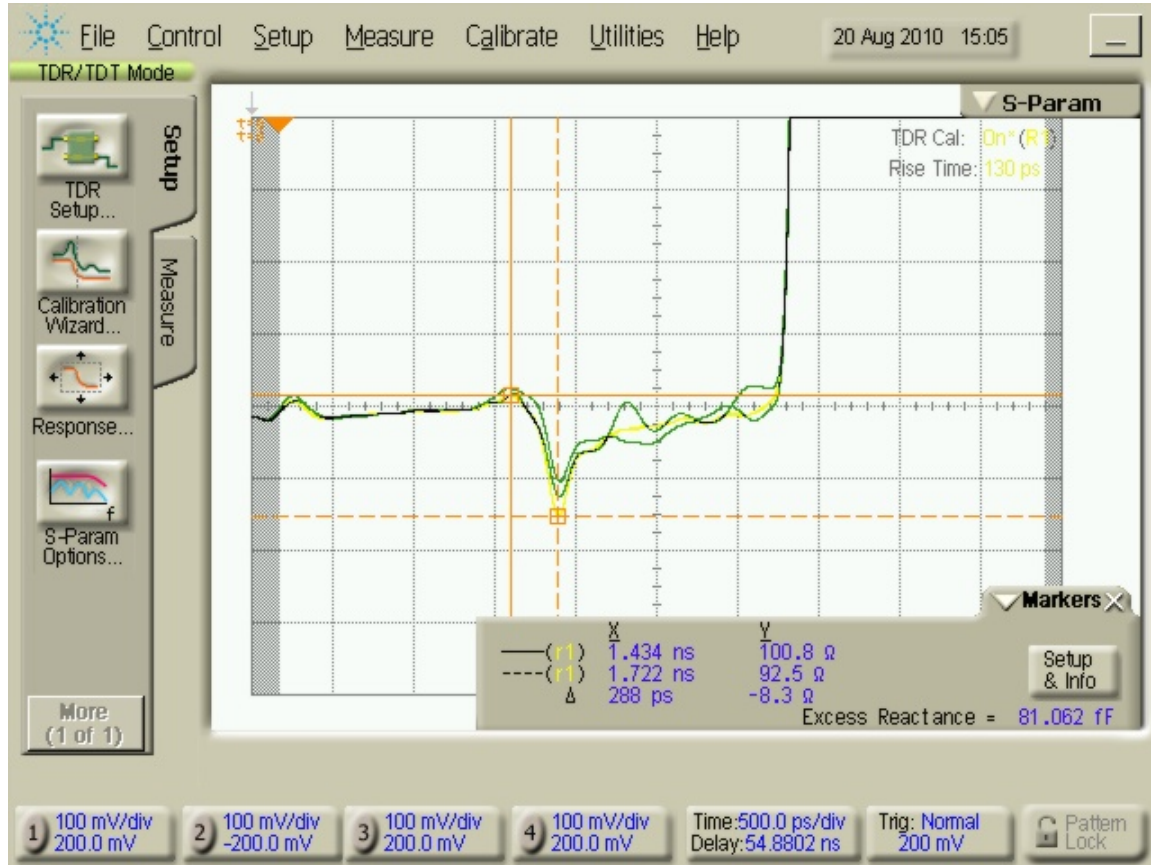

Figure 13. Typical differential TDR of TPA-R connected to Micro-Coax Display Patch cable at 130 ps Rise Time

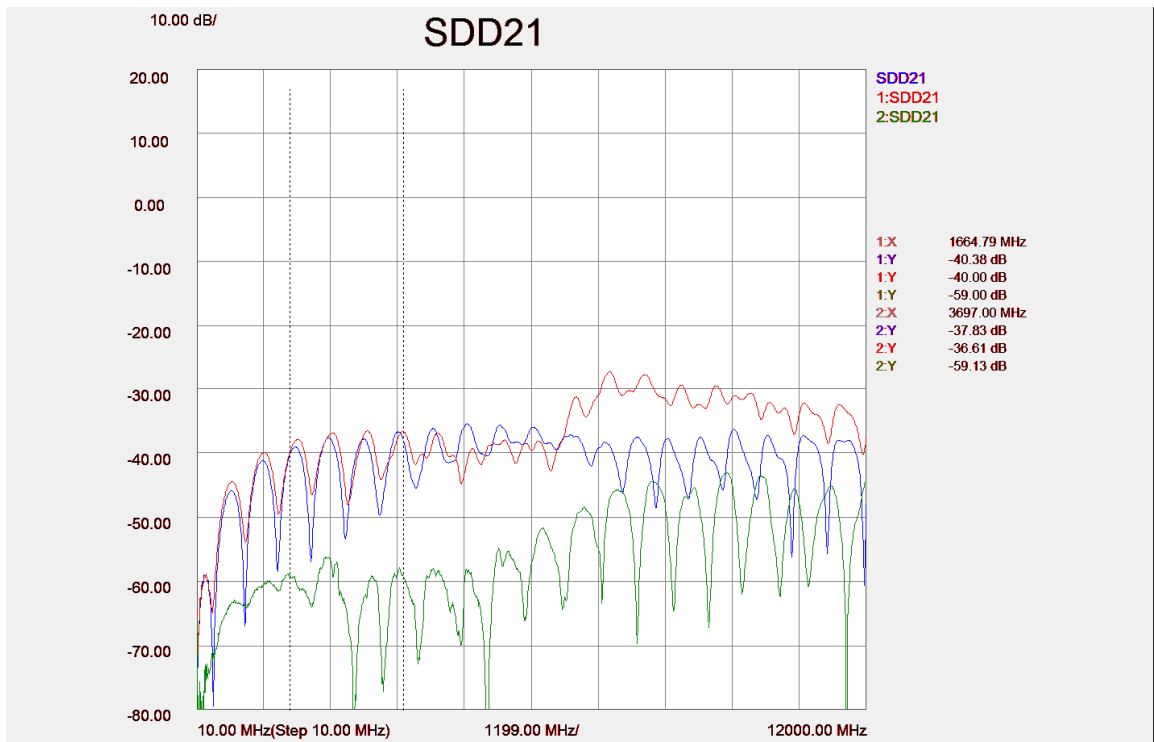
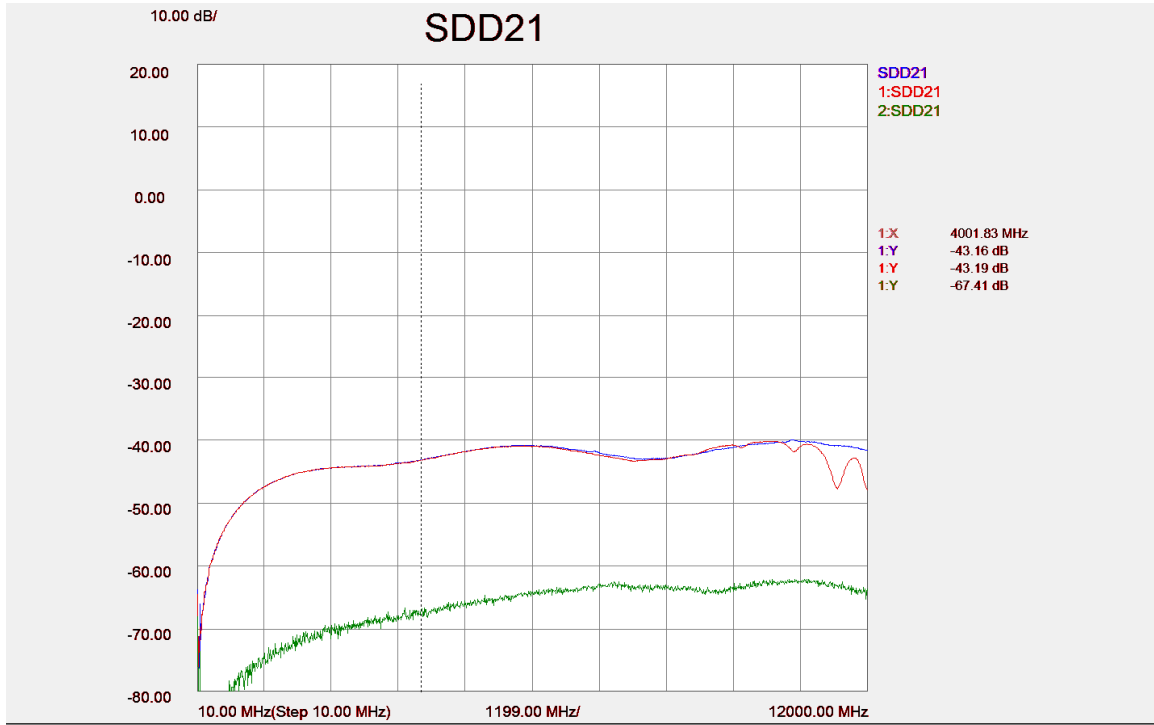

Figure 14. Typical Differential NEXT, without connector (top) and with mated connectors (bottom), all lanes terminated at both ends

Wilder Technologies, LLC – Limited Warranty

Wilder Technologies, LLC warrants that each Embedded DisplayPort Test Adapter, 1) is free from defects in materials and workmanship and, 2) conforms to Wilder Technologies specifications for a period of 12 months. **See Consumable and Fragile Material Warranty for exceptions to the 12 month warranty**

The warranty period for a Test Adapter is a specified, fixed period commencing on the date of ship from Wilder Technologies, LLC. If you did not purchase your Test Adapter directly from Wilder Technologies, LLC, the serial number and a valid proof of purchase will be required to establish your purchase date. If you do not have a valid proof of purchase, the warranty period will be measured from the date of ship from Wilder Technologies, LLC.

If, during the warranty period, the Test Adapter is not in good working order, Wilder Technologies, LLC will, at its option, repair or replace it at no additional charge, except as is set forth below. In some cases, the replacement Test Adapter may not be new and may have been previously installed. Regardless of the Test Adapter's production status, Wilder Technologies, LLC appropriate warranty terms apply.

Consumable and Fragile Material Warranty

Wilder Technologies, LLC warrants that consumable materials, which include but are not limited to I-PEX Micro-Coax Connector and Patch Cable, and all fragile materials supplied by Wilder Technologies, LLC either as part of an instrument or system, or supplied separately, will be free from defects in material and workmanship at the time of shipment. Because of the FRAGILE Nature of the I-PEX Micro-Coax Connector and Patch Cable great care must be exercised when handling.

Extent of Warranty

The warranty does not cover the repair or exchange of a Test Adapter resulting from misuse, accident, modification, unsuitable physical or operating environment, improper maintenance by you, or failure caused by a product for which Wilder Technologies, LLC is not responsible. The warranty is voided by removal or alteration of Test Adapter or parts identification labels. The initial three months are unconditional; the remaining months excludes plugs, receptacles and SMA connectors. Connectors are wear items and excluded from the warranty after the initial three months.

These warranties are your exclusive warranties and replace all other warranties or conditions, express or implied, including but not limited to, the implied warranties or conditions or merchantability and fitness for a particular purpose. These warranties give you specific legal rights and you may also have other rights which vary from jurisdiction to jurisdiction. Some jurisdictions do not allow the exclusion or limitation of express or implied warranties, so the above exclusion or limitation may not apply to you. In that event, such warranties are limited in duration to the warranty period. No warranties apply after that period.

Items Not Covered by Warranty

Wilder Technologies, LLC does not warrant uninterrupted or error-free operation of a Test Adapter.

Any technical or other support provided for a Test Adapter under warranty, such as assistance via telephone with "how-to" questions and those regarding Test Adapter set-up and installation, will be provided **WITHOUT WARRANTIES OF ANY KIND**.

Warranty Service

Warranty service may be obtained from Wilder Technologies, LLC by returning a Wilder Technologies, LLC Returns Material Authorization and the Test Adapter to Wilder Technologies, LLC during the warranty period. To obtain RMA number, contact support@wilder-tech.com.

You may be required to present proof of purchase or other similar proof of warranty entitlement. You are responsible for any associated transportation charges, duties and insurance between you and Wilder Technologies, LLC. In all instances, you must ship Test Adapters in Wilder Technologies, LLC approved packaging. Information on packaging guidelines can be found at: www.wilder-tech.com. Wilder Technologies, LLC will ship repaired or replacement Test Adapter Delivery Duty Prepaid (DDP) and will pay for return shipment. You will receive title to the repaired or replacement Test Adapter and you will be the importer of record.

Wilder Technologies, LLC – Terms & Conditions of Sale

- 1. Other Documents:** This Agreement may NOT be altered, supplemented, or amended by the use of any other document(s) unless otherwise agreed to in a written agreement signed by both you and Wilder Technologies, LLC. If you do not receive an invoice or acknowledgement in the mail, via e-mail, or with your Product, information about your purchase may be obtained at support@wilder-tech.com or by contacting your sales representative.
- 2. Payment Terms, Orders, Quotes, Interest:** Terms of payment are within Wilder Technologies, LLC's sole discretion, and unless otherwise agreed to by Wilder Technologies, LLC, payment must be received by Wilder Technologies, LLC prior to Wilder Technologies, LLC's acceptance of an order. Payment for the products will be made by credit card, wire transfer, or some other prearranged payment method unless credit terms have been agreed to by Wilder Technologies, LLC. Invoices are due and payable within the time period noted on your invoice, measured from the date of the invoice. Wilder Technologies, LLC may invoice parts of an order separately. Your order is subject to cancellation by Wilder Technologies, LLC, in Wilder Technologies, LLC's sole discretion. Unless you and Wilder Technologies, LLC have agreed to a different discount, Wilder Technologies, LLC's standard pricing policy for Wilder Technologies, LLC-branded systems, which includes hardware, software and services in one discounted price, allocates the discount off list price applicable to the service portion of the system to be equal to the overall calculated percentage discount off list price on the entire system. Wilder Technologies, LLC is not responsible for pricing, typographical, or other errors in any offer by Wilder Technologies, LLC and reserves the right to cancel any orders resulting from such errors.
- 3. Shipping Charges; Taxes; Title; Risk of Loss:** Shipping, handling, duties and tariffs are additional unless otherwise expressly indicated at the time of sale. Title to products passes from Wilder Technologies, LLC to Customer on shipment from Wilder Technologies, LLC's facility. Loss or damage that occurs during shipping by a carrier selected by Wilder Technologies, LLC is Wilder Technologies, LLC's responsibility. Loss or damage that occurs during shipping by a carrier selected by you is your responsibility. You must notify Wilder Technologies, LLC within 7 days of the date of your invoice or acknowledgement if you believe any part of your purchase is missing, wrong or damaged. Unless you provide Wilder Technologies, LLC with a valid and correct tax exemption certificate applicable to your purchase of Product and the Product ship-to location, you are responsible for sales and other taxes associated with the order. **Shipping dates are estimates only.**
- 4. WARRANTY:** WILDER TECHNOLOGIES, LLC, warrants that the item(s) manufactured under the Buyer's contract shall be free from defects in materials and workmanship furnished by WILDER TECHNOLOGIES, LLC, and shall conform to the applicable drawings and specifications. WILDER TECHNOLOGIES, LLC'S liability herein, for breach of warranty, contract or negligence in manufacturing, shall be limited to repair or replacement. Repair or replacement of defective items will be applicable only if the Buyer notifies WILDER TECHNOLOGIES, LLC, by written notice within 30-days of delivery. All claims shall be addressed to: support@wilder-tech.com or WILDER TECHNOLOGIES, LLC, 6101A East 18th Street, Vancouver, Washington 98661 U.S.A.; ATTENTION: Customer Service Manager. WILDER TECHNOLOGIES, LLC, reserves the right to inspect at the Buyer's plant all items claimed to be defective or nonconforming prior to authorizing their return. WILDER TECHNOLOGIES, LLC, assumes no liability for the results of the use of its components in conjunction with other electric, electronic or mechanical components, circuits and/or systems. The foregoing constitutes the sole and exclusive remedy of the Buyer and the exclusive liability of WILDER TECHNOLOGIES, LLC, and is IN LIEU OF ANY AND ALL OTHER WARRANTIES, STATUTORY, IMPLIED OR EXPRESSED AS TO MERCHANTABILITY, FITNESS FOR THE PURPOSE SOLD, DESCRIPTION, QUALITY, and PRODUCTIVENESS OR ANY OTHER MATTER. Without limiting the foregoing, in no event shall WILDER TECHNOLOGIES, LLC, be liable for loss of use, profit or other collateral, or for special and/or consequential damages.
- 5. RETURNED GOODS:** WILDER TECHNOLOGIES, LLC, will accept only those goods for return that have been authorized for return. All goods authorized for return shall be assigned a Returned Material Authorization (RMA) Number. The RMA Number shall be clearly marked on the shipping container(s) and all documentation accompanying the goods authorized for return. The RMA Number shall be assigned by WILDER TECHNOLOGIES, LLC pursuant to the conditions set forth in Paragraph 4, WARRANTY.
- 6. UNITED STATES GOVERNMENT CONTRACTS:** In the event this offer is accepted under Government contract, WILDER TECHNOLOGIES, LLC, agrees to accept clauses required by Government regulations and to waive WILDER TECHNOLOGIES, LLC conditions inconsistent therewith. WILDER TECHNOLOGIES, LLC, certifies that it is a regular manufacturer or dealer of the goods and/or services offered herein and that the prices offered do not exceed those charged to any customer for like quantities, services or materials under the same conditions.

Compliance with Environmental Legislation

Wilder Technologies, LLC, is dedicated to complying with the requirements of all applicable environmental legislation and regulations, including appropriate recycling and/or disposal of our products.



WEEE Compliance Statement

The European Union adopted Directive 2002/96/EC on Waste Electrical and Electronic Equipment (WEEE), with requirements that went into effect August 13, 2005. WEEE is intended to reduce the disposal of waste from electrical and electronic equipment by establishing guidelines for prevention, reuse, recycling and recovery.

Wilder Technologies has practices and processes in place to conform to the requirements in this important Directive.

In support of our environmental goals, effective January 1st, 2009 Wilder Technologies, LLC has partnered with E-Tech Recycling of Beaverton, Oregon, www.etchrecycling.com, to recycle our obsolete and electronic waste in accordance with the European Union Directive 2002/96/EC on waste electrical and electronic equipment ("WEEE Directive").

As a service to our customers, Wilder Technologies is also available for managing the proper recycling and/or disposal of all Wilder Technologies products that have reached the end of their useful life. For further information and return instructions, contact support@wilder-tech.com.

Glossary of Terms

TERMINOLOGY	DEFINITION
Aggressor	A signal imposed on a system (i.e., cable assembly) to measure response on other signal carriers.
AUX Channel	A half-duplex, bi-directional channel within the DisplayPort interface; short for “Auxiliary Channel”. Consists of one differential pair transporting self-clocked data. The DisplayPort AUX Channel supports a bandwidth of 1Mbps. The DisplayPort Source is the master that initiates an AUX Channel transaction. The DisplayPort Sink is the slave (also referred to as AUX Channel Replier) that replies to the AUX Channel transaction initiated by the Requester.
DisplayPort Receiver	Circuitry that receives the incoming DisplayPort Main Link data. Also contains the transceiver circuit for AUX Channel. Located in Sink Device and in the upstream port of any Intermediate Device.
DisplayPort Transmitter	Circuitry that transmits the DisplayPort Main Link data. Also contains the transceiver circuit for AUX CH. Located in Source Device and in the downstream port of Intermediate Device.
EDP-TPA	Embedded DisplayPort Test Point Access. A specialized assembly that interfaces to a Embedded DisplayPort plug and enables access of signals for measurement or stimulation.
EMI	Electro-Magnetic Interference
HPD	Hot Plug Detect
Informative	The designation of a test that is not required for compliance but is considered important from a characterization standpoint. It is provided for informational purposes only.
Main Link	Unidirectional channel for isochronous stream transport from Embedded DisplayPort Source to Embedded DisplayPort Sink. Consists of 1 or 2 lanes, or differential pairs. Supports 2 bit rates: 2.7Gb/s per lane (referred to as “High Bit Rate”) and 1.62Gb/s per lane (referred to as “Reduced Bit Rate”).
NEXT	Near-end Crosstalk
Normative	The designation of a test that is required for compliance.
Sink Device	Contains one sink function and at least one rendering function, and is a Leaf Device in a DisplayPort tree topology. A device that receives A/V stream sinks for video display and/or sound reproduction.
Source Device	A device that contains an A/V stream source and originates an isochronous A/V stream.
Victim	A signal carrier on a system that has a response imposed on it by other signals in the system.

Index

- 1X-THRU, 15
- BL_ENABLE, 3
- BL_GND, 3
- BL_PWM_DIM, 3
- BL_PWR, 3
- Cable Bend Limits, 6
- Cable Losses, 15
- Cable Tension (Pull Forces), 6
- Cable Twisting (Torque), 6
- Calibration, 13
- Care and Handling, 6
- Cleaning, 8
- Compliance
 - WEEE, 32
- Connections
 - EDP-TPA to DUT, 6
 - SMA, 7
- Crosstalk errors, 14
- de-emphasis, 15
- Directivity errors, 14
- DisplayPort CTS PHY 1.1, 10
- drift errors, 14
- DUT, 14
- EDP-TPA Cable Pinout, 16
- Electrical Specifications, 20
- Electrostatic Discharge Information (ESD), 9
- Embedded DisplayPort TPA and Micro-Coax Cable as a sink, 10
- Embedded DisplayPort TPA and Micro-Coax Cable as a source, 11
- Embedded DisplayPort TPAs as a source and sink, 12
- environmental changes, 14
- Errors
 - Crosstalk*, 14
 - Directivity*, 14
 - drift*, 14
 - Load Impedance Mismatching*, 14
 - random*, 14
 - Receiver Reflection-tracking in Test Equipment*, 14
 - Receiver Transmission in Test Equipment*, 14
 - Source Impedance Mismatching*, 14
- ESD protection, 9
- Figures
 - As-Tested Configuration, 21
 - Cable Connectors, 16
 - Calibration module, 13
 - The eDP DisplayPort Test Adapter (Receptacle with Patch Cable), 4
 - The eDP DisplayPort Test Adapter (Receptacle), 3
- Flip-Lock Feature, 6
- Glossary, 33
- Group Delay, 15
- Handling and storage, 8
- Hot Plug Detect, 3
- LCD_GND, 3
- LCD_Self_Test, 3
- LCD_VCC, 3
- Load Impedance Mismatching errors, 14
- low-speed connector, 3, 4
- Low-Speed Connector Part Numbers, 4
- Making Connections, 8
- Mechanical and Environmental Specifications, 16
- Molex part numbers, 4
- NC – Reserved, 3
- pre-emphasis, 15
- Product Inspection, 5
- product return, 5
- pull force, 7
- random errors, 14
- Receiver Reflection-tracking in Test Equip. errors, 14
- Receiver Transmission in Test Equip. errors, 14
- secure storage, 5
- SMA cables, 16
- SOLT, 14
- Source Impedance Mismatching errors, 14
- Support, 31
- Supporting Instrument Cables or Accessories, 7
- Swing-Latch, 6
- Tables
 - EDP Receptacle Pin Assignments, 19
 - EDP-TPA 20-Position Cable Connector, 18
 - Electrical Specifications, 20
 - General Specifications, 16
 - SMA Cable Connectors (High-Speed), 17
- Terms and Conditions of Sale, 31
- test instrument noise, 14
- test repeatability problems, 14
- User Model Examples, 10, 11, 12
- VESA DisplayPort™ PHY Compliance Test Spec., 3
- Visual inspection, 8
- Warranty, 30
- Web Sites
 - support@wilder-tech.com, 30, 31
 - www.etechnology.com, 32
 - www.wilder-tech.com, 30
- WEEE, 32

Visit our website at www.wilder-tech.com



Wilder Technologies, LLC
6101A East 18th Street
Vancouver, WA 98661
Phone: 360-859-3041
Fax: 360-859-3105
www.wilder-tech.com

© 2010 Wilder Technologies, LLC
Document No. 910-0003-000 Rev. B
Created: 1/7/2010, Revised: 8/20/2010